

Features

Modular TrueAlarm sensor base with built-in electronic alarm sounder:

- Piezoelectric sounder provides high output (88 dBA) with low current requirements (20 mA)
- For use with interchangeable TrueAlarm photoelectric or heat sensors (ordered separately)
- Operation is for ceiling or wall mounting

Sounder operation details:

- Powered from 24 VDC or from a compatible Notification Appliance Circuit (NAC)
- Synchronized via communications or by the NAC, if NAC powered**
- Sounder can be manually activated from the control panel
- Sensor and sounder operation is listed to UL Standard 268
- Sounder operation is also listed to UL Standard 464 as an audible notification appliance

TrueAlarm analog sensing operation:

- Analog sensor information is digitally communicated to the control panel via IDNet or MAPNET II two-wire communications
- Sensor information is processed by the control panel to determine sensor status

For use with the following Simplex® products:

- 4007ES, 4010, 4010ES, 4100ES, and 4100U Series control panels; and 4008 Series control panels with reduced feature set (refer to data sheet S4008-0001 for details)
- 4020, 4100, and 4120 Series control panels, and Universal Transponders equipped for MAPNET II operation

General features:

- Louvered smoke sensor design enhances smoke capture by directing flow to chamber; entrance areas are minimally visible when ceiling mounted
- Designed for EMI compatibility
- Magnetic test feature is provided
- Optional accessories include remote LED alarm indicator and output relays

Additional base reference:

- For standard bases, refer to data sheet S4098-0019
- For isolator bases, refer to data sheet S4098-0025
- For photo/heat sensors, refer to data sheet S4098-0024 (single address) and S4098-0033 (dual address)

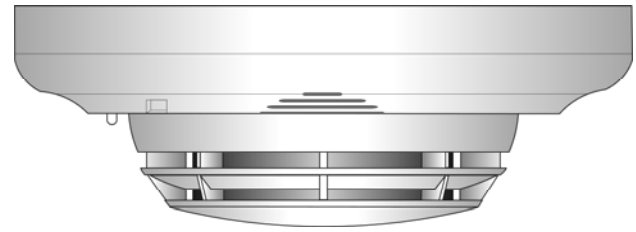

TrueAlarm Photoelectric Sensor Mounted in
Sounder Base 4098-9794

TrueAlarm Analog Sensing Description

Sounder bases combine an audible notification appliance and a TrueAlarm analog sensor to provide:

Digital Communication of Analog Sensing.

Sensors provide an analog measurement that is digitally communicated to the control panel where it is analyzed and an average value is determined and stored. An alarm or other abnormal condition is determined by comparing the sensor's present value against its average value.

Intelligent Data Evaluation. Monitoring each sensor's average value provides a software filtering averaging process that compensates for environmental factors (dust, dirt, etc.) and component aging, providing an accurate reference for evaluating new activity. The result is a significant reduction in the probability of false or nuisance alarms caused by shifts in sensitivity, either up or down.

Control Panel Selection. Peak activity per sensor is stored to assist in evaluating specific locations. The alarm set point for each TrueAlarm sensor is determined at the control panel, selectable as more or less sensitive as the individual application requires.

Timed/Multi-Stage Selection. Alarm set points can be programmed for timed automatic sensitivity selection (such as more sensitive at night, less sensitive during day). Control panel programming can also provide multi-stage operation per sensor. For example, a 0.2% level may cause a warning to prompt investigation while a 2.5% level may initiate an alarm.

Sensor Alarm and Trouble LED Indication. Each sensor base's LED pulses to indicate communications with the panel. If the control panel determines that a sensor is in alarm, or that it is dirty or has some other type of trouble, the details are announced at the control panel and that sensor base's LED will be turned on steadily. During a system alarm, the control panel will control the LEDs such that an LED indicating a trouble will return to pulsing to help identify the alarmed sensors.

* This product has been approved by the California State Fire Marshal (CSFM) pursuant to Section 13144.1 of the California Health and Safety Code. See CSFM Listings 7300-0026:217 and 7271-0026:231 for allowable values and/or conditions concerning material presented in this document. Accepted for use – City of New York Department of Buildings – MEA35-93E. Additional listings may be applicable, contact your local Simplex product supplier for the latest status. Listings and approvals under Simplex Time Recorder Co. are the property of Tyco Fire Protection Products.

** Total quantity of sounder bases available for coding on the same communications channel may vary with panel application and availability of NAC power. Refer to specific control panel requirements.

Additional Sounder Base Features

Base mounted address selection allows the address to remain with its programmed location when the sensor is removed for service or type change. Access is from the front under the removable sensor.

Automatic sensor type identification provides default sensitivity when substituting sensor types. Different sensor types can be easily interchanged to meet specific location requirements. This feature also allows intentional sensor substitution during building construction. When conditions are temporarily dusty, instead of covering the smoke sensors (causing them to be disabled), heat sensors may be installed without reprogramming the control panel.

Integral red LED indicates power-on by pulsing, or alarm or trouble when steady on. The exact status is annunciated at the fire alarm control panel.

Fire alarm control panel provides:

- Peak value logging allowing accurate analysis of each sensor for individual sensitivity selection
- Sensitivity monitoring satisfying NFPA 72 sensitivity testing requirements; automatic individual sensor calibration check verifies sensor integrity
- Automatic environmental compensation, multi-stage alarm operation, and display of sensitivity directly in percent per foot
- Ability to display and print detailed sensor information in plain English language

Accessories

4098-9822, LED Annunciation Relay activates when base LED is on steady, indicating a local alarm or trouble. Contacts are DPDT, rated 2 A @ 30 VDC; 1/2 A @ 120 VAC for transient suppressed loads (requires external 24 VDC coil power).

2098-9808, Remote red LED Alarm Indicator mounts on a single gang box to provide status indications where the sensor location may not be readily visible.



2098-9808 Remote LED Alarm Indicator

Mounting Reference

Electrical Box Requirements: (boxes are by others)

Without relay: 4" octagonal or 4" square, 1-1/2" deep; single gang, 2" deep

With relay: 4" octagonal or 4" square, 1-1/2" deep, with 1-1/2" extension ring

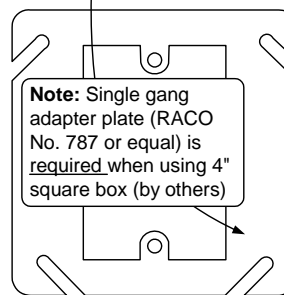
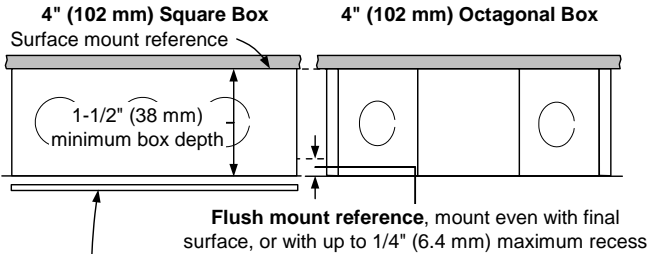

Optional 4098-9822 Relay
(Mounts in base electrical box and requires additional volume, see notes below)

Relay size:
2-1/2" X 1-1/2" X 1"
(64 mm X 38 mm X
25.4 mm), 3.75 cubic inches

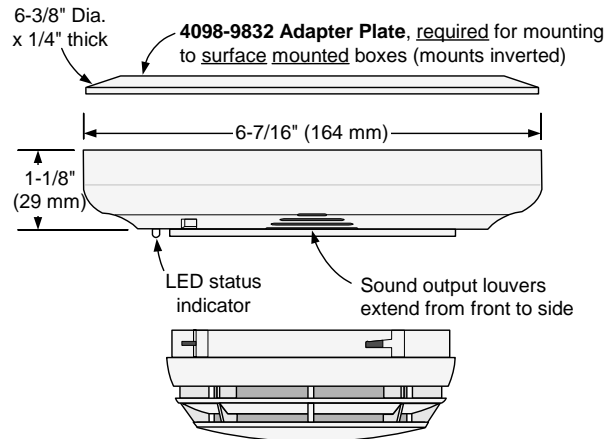
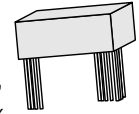

NOTES:

1. Review actual wire size, wire count, box type, and whether 4098-9822 relay is used before determining box size.
2. Mounting to flush mounted box also fits single gang handy box, 2-1/8" (51 mm) deep if wiring allows. (Not applicable if 4098-9822 relay is used.)
3. For surface mounted boxes, use 4" square box with single gang adapter plate (RACO No. 787 or equal, by others) or 4" octagonal box, both require 4098-9832 Adapter Plate.
4. When 4098-9822 relay is used, mount relay in electrical box and use 1-1/2" extension ring (by others) on 4" square or octagonal box of 1-1/2" or 2-1/8" depth as required.
5. Refer to Installation Instructions 574-707 for additional information.

TrueAlarm Analog Sensor Features

Sealed against rear air flow entry

Electronics are EMI/RFI shielded

Heat sensors:

- Selectable rate compensated, fixed temperature sensing with or without rate-of-rise operation
- Rated spacing distance between sensors:

Fixed Temp. Setting	UL & ULC Spacing	FM Spacing, Either Fixed Temperature Setting
135° F (57.2° C)	60 ft x 60 ft (18.3 m)	20 ft x 20 ft (6.1 m) for fixed temperature only; RTI = Quick
155° F (68° C)	40 ft x 40 ft (12.2 m)	50 ft x 50 ft (15.2 m) for fixed temperature with either rate-of-rise selection; RTI = Ultra Fast

Smoke Sensors:

- Photoelectric technology sensing
- 360° smoke entry for optimum response
- Built-in insect screens

4098-9714 Photoelectric Sensor

TrueAlarm photoelectric sensors use a stable, pulsed infrared LED light source and a silicon photodiode receiver to provide consistent and accurate low power smoke sensing. Seven levels of sensitivity are available for each individual sensor, ranging from 0.2% to 3.7% per foot of smoke obscuration. Sensitivities of 0.2%, 0.5%, and 1% are for special applications in clean areas. Standard sensitivities are 1.5%, 2.0%, 2.5%, 3.0%, and 3.7%. Application type and sensitivity are selected and then monitored at the fire alarm control panel.*

The sensor head design provides 360° smoke entry for optimum smoke response. Due to its photoelectric operation, air velocity is not normally a factor, except for impact on area smoke flow.

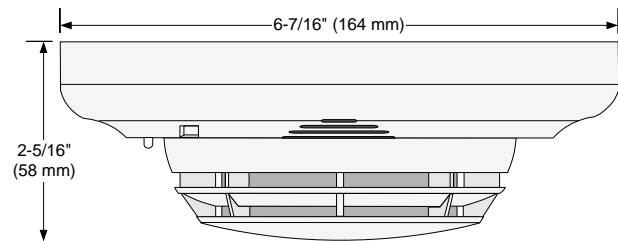

4098-9714 Photoelectric Sensor with Sounder Base

4098-9733 Heat Sensor

TrueAlarm heat sensors are self-restoring and provide rate compensated, fixed temperature sensing, selectable with or without rate-of-rise temperature sensing. Due to its small thermal mass, the sensor accurately and quickly measures the local temperature for analysis at the fire alarm control panel.

Rate-of-rise temperature detection is selectable at the control panel for either 15° F (8.3° C) or 20° F (11.1° C) per minute. Fixed temperature sensing is independent of rate-of-rise sensing and programmable to operate at 135° F (57.2° C) or 155° F (68° C). In a slow developing fire, the temperature may not increase rapidly enough to operate the rate-of-rise feature. However, an alarm will be initiated when the temperature reaches its rated fixed temperature setting.

TrueAlarm heat sensors can be programmed as a utility device to monitor for temperature extremes in the range from 32° F to 155° F (0° C to 68° C). This feature can provide freeze warnings or alert to HVAC system problems. *Refer to specific panels for availability.*

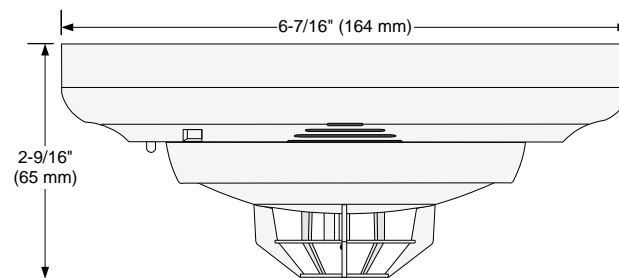

4098-9733 Heat Sensor with 4098-9794 Sounder Base

WARNING: In most fires, hazardous levels of smoke and toxic gas can build up before a heat detection device would initiate an alarm. In cases where Life Safety is a factor, the use of smoke detection is highly recommended.

Application Reference

Sensor locations should be determined after careful consideration of the physical layout and contents of the area to be protected. Refer to NFPA 72, the *National Fire Alarm and Signaling Code*. On smooth ceilings, smoke sensor spacing of 30 ft (9.1 m) may be used as a guide. For detailed application information, refer to *4098 Detectors, Sensors, and Bases Application Manual*, Part Number 574-709.*

* For detailed application information including sensitivity selection, refer to Installation Instructions 574-709.

TrueAlarm Analog Sensing Product Selection Chart

TrueAlarm Sounder Base*

Model	Description	Compatibility	Mounting Requirements
4098-9794	Sounder Base with connections for Remote LED Alarm Indicator or Unsupervised Relay	Sensors: 4098-9714 and 4098-9733 Options: 2098-9808 remote LED alarm indicator or 4098-9822 relay	Refer to page 2, mounting reference

TrueAlarm Sensors (ordered separately)

Model	Description	Mounting Requirements
4098-9714	Photoelectric Smoke Sensor	Refer to page 2, mounting reference
4098-9733	Heat Sensor	

Sounder Base Accessories (ordered separately if required)

Model	Description	Mounting Requirements
4098-9832	Adapter Plate, required for surface mounted 4" electrical boxes	Refer to page 2, mounting reference
2098-9808	Choose one if required	Remote red LED Alarm Indicator on single gang stainless steel plate
4098-9822		Relay, tracks base LED status (unsupervised, to be mounted only in base electrical box)

* Refer to data sheet S4098-0019 for other compatible bases. Refer to Installation Instructions 574-707 and Application Manual 574-709 for additional information.

Specifications

General Operating Specifications

Communications and Sensor Supervisory Power	IDNet or MAPNET II communications, auto-selected, 1 address per base	
Communications and Sounder Power Connections	Screw terminals for in/out wiring, 18 to 14 AWG (0.82 mm ² to 2.08 mm ²)	
Remote LED Alarm Indicator	Current	1 mA typical supplied from communications, no impact to alarm current
	LED Connections	Color coded wire leads, 18 AWG (0.82 mm ²)
UL Listed Temperature Range	32° F to 100° F (0° C to 38° C)	
Operating Temperature Range	With 4098-9733	32° F to 122° F (0° C to 50° C)
	With 4098-9714	15° F to 122° F (-9° C to 50° C)
Storage Temperature Range	0° F to 140° F (-18° C to 60° C)	
Humidity Range	10 to 95% RH	
Smoke Sensor Ambient Ratings	4098-9714, Photoelectric Sensor	Air velocity is 0-4000 ft/min (0-1220 m/min)
Housing Color	Frost White	

Sounder Operation

Sounder Voltage	18 to 32 VDC from steady external source or from NAC	
Alarm Current (Sounder On)	20 mA @ 24 VDC, 24 mA maximum @ 32 VDC	
Sounder Output	88 dBA minimum @ 10 ft (3 m) per UL Standard 464, <i>Audible Signaling Appliances</i> and UL Standard 268, <i>Smoke Detectors for Fire Protective Signaling Systems</i>	
Sounder Power Supervision (Selectable)	Supervised	Select for continuous 24 VDC power, loss of power is communicated to panel
	Unsupervised	Select when connected to NAC for sounder power, NAC provides supervision
NAC Powered Operation	When in alarm, will sound when NAC is in alarm, allowing synchronized pattern (Temporal or March Time, etc.) controlled by the NAC	

4098-9822 Unsupervised Relay Option

Externally Supplied Relay Voltage	18-32 VDC, steady source recommended (wires to remote LED leads)
Alarm Current	13 mA from separate 24 VDC supply
Contact Ratings, DPDT contacts for resistive/suppressed loads	Power limited rating: 2 A @ 30 VDC
	Non-power limited rating: 1/2 A @ 120 VAC
Relay Operation	Tracks base LED status, relay is on with trouble or alarm at the base

TYCO, SIMPLEX, and the product names listed in this material are marks and/or registered marks. Unauthorized use is strictly prohibited. NFPA 72 and National Fire Alarm and Signaling Code are trademarks of the National Fire Protection Association (NFPA).



Tyco Fire Protection Products • Westminster, MA • 01441-0001 • USA

S4098-0028-11 1/2015

www.simplex-fire.com

© 2015 Tyco Fire Protection Products. All rights reserved. All specifications and other information shown were current as of document revision date and are subject to change without notice.